

ID tolerance per customer requirements.

VIEW 1

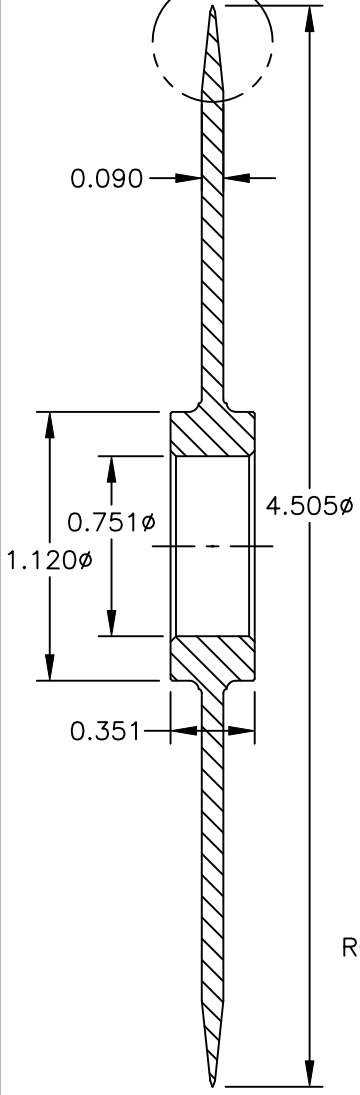

SECTION A-A

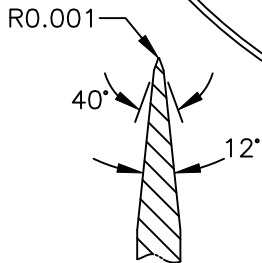

VIEW 1  
(2X SIZE)

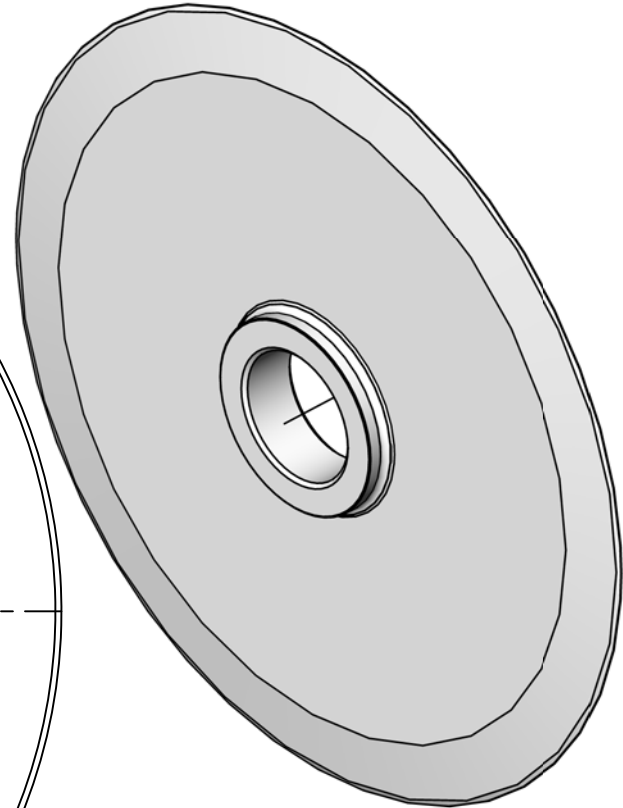
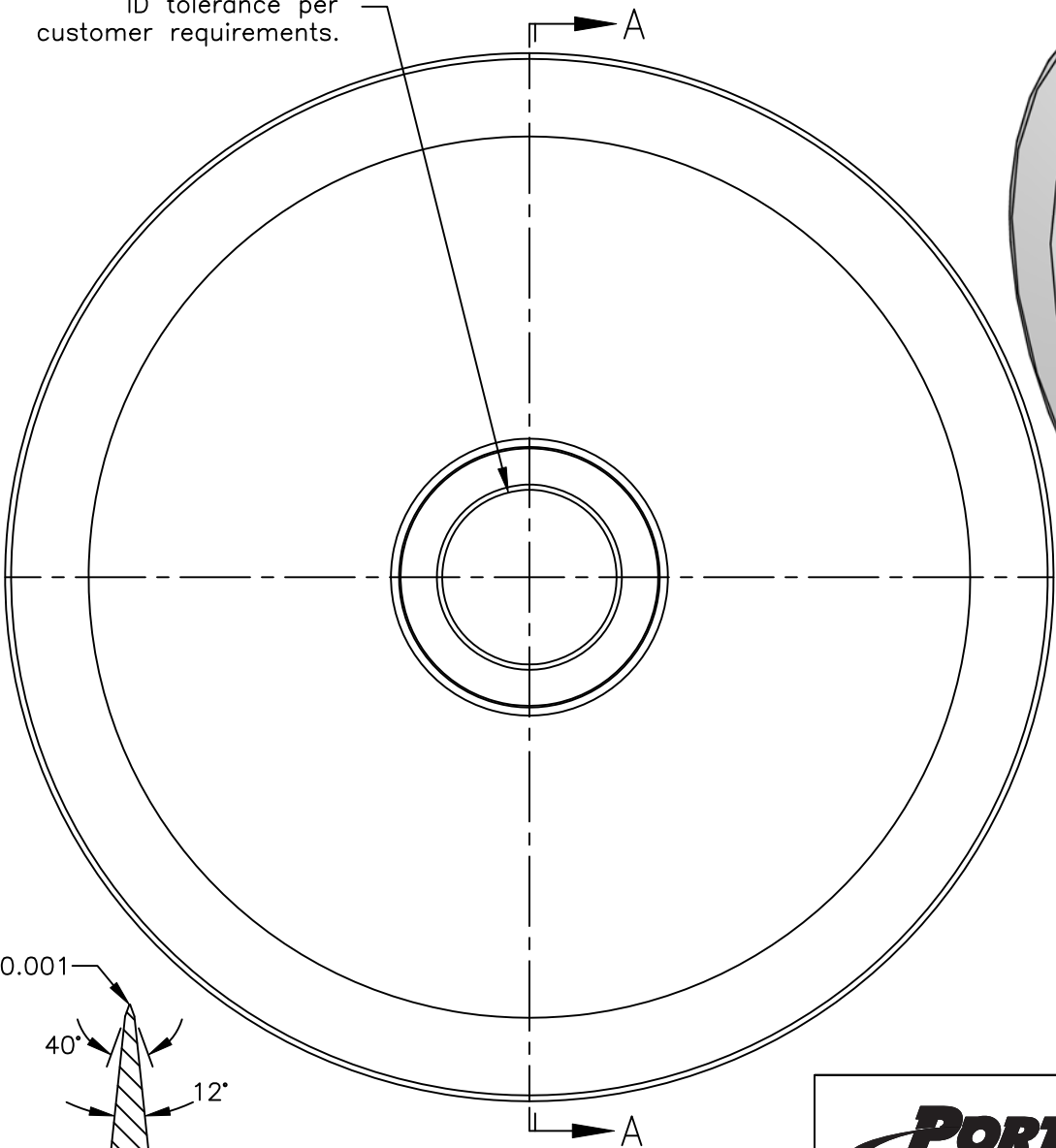

Website Drawing

**PORTAGE KNIFE COMPANY**

MANUFACTURER OF  
SCORE SLITTERS  
AND PERFORATORS

A DIVISION OF PORTAGE MACHINE CONCEPTS, INC. AKRON, OHIO (330) 784-0700

455-40-001 Circular Knife

SIZE A	DWG NAME: 455-40.dwg
-----------	-------------------------

- Unless noted otherwise, all dimensions are nominal.
- Circular knife is manufactured from [52100] material, heat treated to a hardness of [60-62] HRC.

This print and the intellectual content is the property of Portage Machine Concepts, Inc. and must not be copied, transmitted or disseminated, in any way, without the written permission of Portage Machine Concepts, Inc.

SCALE: NONE	DATE: 10/6/2022	DRAWN: D. MILLER	SHEET: 1
-------------	-----------------	------------------	----------